



## CERAMOTHERM<sup>®</sup> 3000

One radiant warmer for all applications  
Baby changing, Examination, Intensive care

## Sensible cosy and gentle warming

In various situations patients need support to maintain their body temperature. This applies to unclothed babies during nappy changing, infants under longer examination, centralized patients and theatre preparation and recovery. Infrared radiant warmers are ideal for this purpose. But which is the right one?

Infra-red radiation is part of the solar spectrum and invisible for human beings. It is divided in three ranges according to their wave-length.

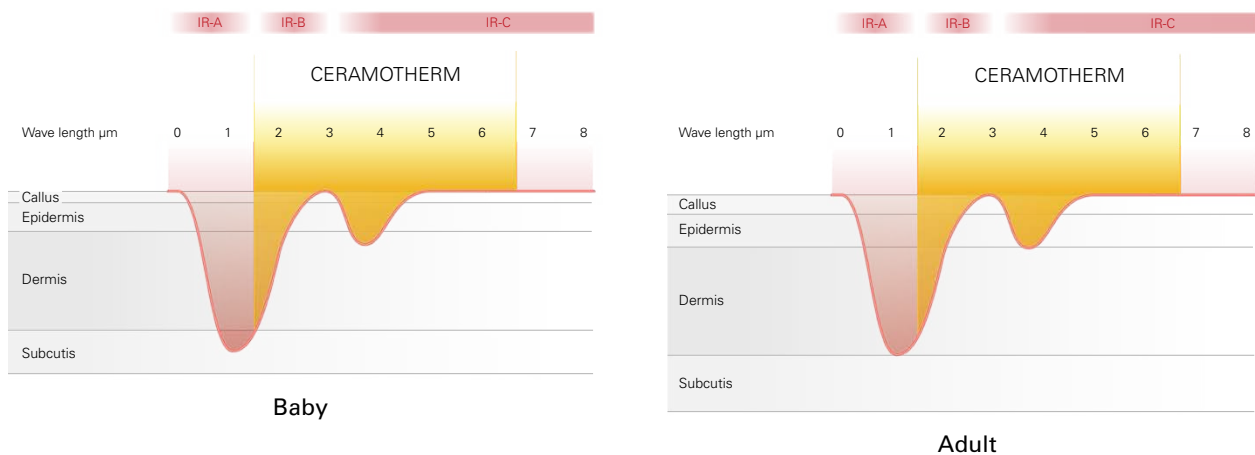

### IR-A

Near infrared radiation (0.78-1.4 μm) – penetrates deeply into the subcutaneous tissue and has a deep warming effect. The eye is transparent for near infrared shares and **injuries of the retina** can occur without advance warning. Therefore IR-A radiation should only be used for certain intensive-therapeutic applications under medical surveillance. Sufficient eye protection is mandatory and it must be secured that it cannot slip off. Keeping in mind the deep penetration in particular the thin skin of babies and preterm babies must be protected from burning injuries.

### IR-B

Medium infrared radiation (1.4-3.0 μm) – reaches the medium skin layers (dermis) with the effect of warming the Epidermis and the dermis below as well as the bloodstream.

### IR-C

Far infrared radiation (3.0-10 μm) – mainly penetrates into the upper skin layers only, with the effect of an even and gentle warming of the human body.

## Radiant warmers CERAMOTHERM

Radiant warmers CERAMOTHERM supply infra-red radiation in the wave length spectrum of **1.5 - 6.8 μm (IR-B + IR-C)**, according to the surface temperature of their ceramic heating elements.

When medium and far infrared rays reach the human body, they are absorbed by the upper skin layers and converted into heat. But they do not penetrate deeply into the radiation-sensitive tissue layers. The blood circulation is increased and the warmed blood is transported and distributed in the body.

CERAMOTHERM infrared radiation is gently, safely and at the same time efficiently converted into sensible cosy body heat.

# The radiant warmer

Radiant Warmers CERAMOTHEM are the result of nearly 40 years of continuous development in the medical use of infrared radiation. Convenient handling and function, comfortable operation as well as a safe use are the priorities of this radiant warmer.

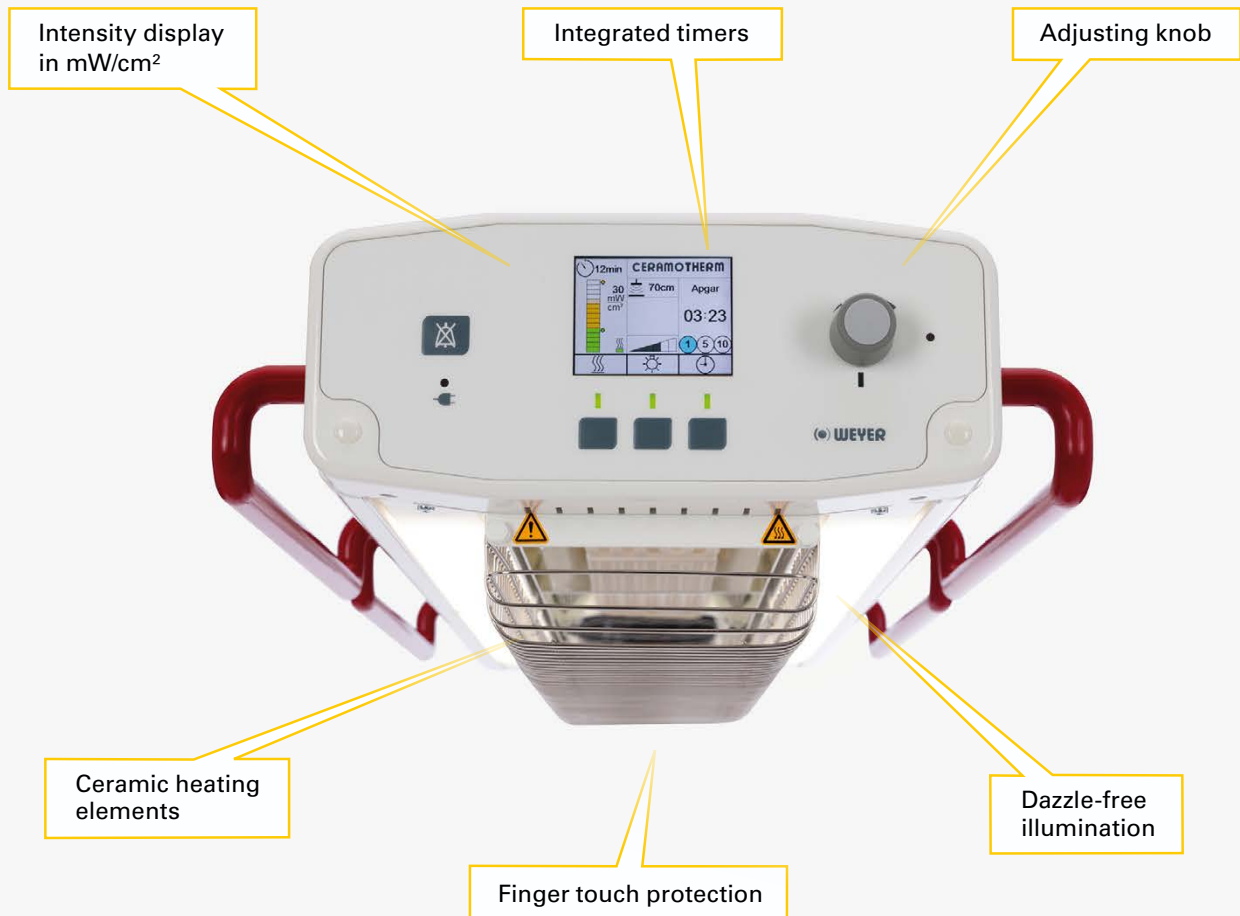

# CERAMOTHERM® 3000

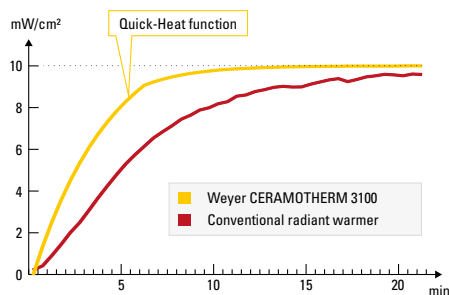

## Impressive warming efficiency

Infrared rays do not warm-up the ambient air but are absorbed by the bodies they impinge on and are so converted into heat. By the new developed high-performance reflector the heat is directed to the patient pad even more efficiently and evenly. The **Quick-Heat function** produces the required warming energy within shortest time and outshines conventional radiant heaters.

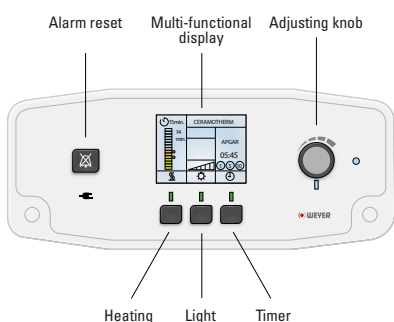

## Easy to operate

Same as the well-proven product series THERMOCARE and VARIO THERM, intensity and light are selected intuitively according to the principle "Select - Adjust - Confirm".

So an unintentional direct adjustment, e.g. by visitors, is prevented.

At different light conditions (day, night) the brightness of the colour display is automatically adapted to the ambience, so the display can be read-off clearly at any time. When the device has cooled down after switch-off, the display is darkened, so the night's sleep is not disturbed.

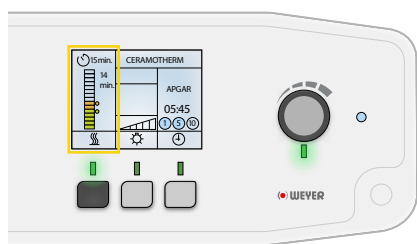

## Intensity adjustment as required

Rough settings of heating capacity in steps are a thing of the past. In particular for small infants a sensitive adjustment of the radiation intensity according to their demand is a must.

The CERAMOTHERM system allows a fine adjustment of the intensity in  $mW/cm^2$ , optionally in %.

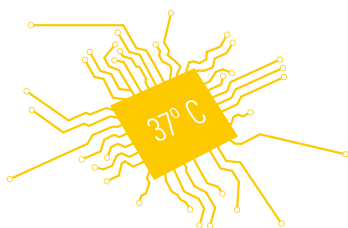

The selected intensity emitted to the patient is calculated by a processor according to the distance to the patient pad. It is controlled precisely and indicated in the actual intensity display.

This technique allows maintaining the body temperature in adults, infants and even smallest preterm babies during intensive care.



## Homogeneous illumination

For the smallest patients the best light is just good enough. Infants, in particular new born babies, are stressed when they are dazzled by a sudden glaring spot-light.

Therefore the large-area lamps of the CERAMOTHERM 3000 switch on and off the light gently. Small patients remain calm and feel cosy.

The colour temperature of the light is 4000 Kelvin which guaranties an excellent appearance and is suitable for examination and minor operations. The illumination intensity can be adapted in 5 steps according to the actual situation. So the optimum light is always available.



## Integrated timers

With the 3 integrated timers the radiant warmer CERAMOTHERM is a device for versatile use.

→ Apgar-Timer. For postnatal care of new born babies.

→ Stop watch. Helpful in many applications.

→ Countdown-timer: Always indispensable for applications with limited time frame (in the action range of the radiant warmer).

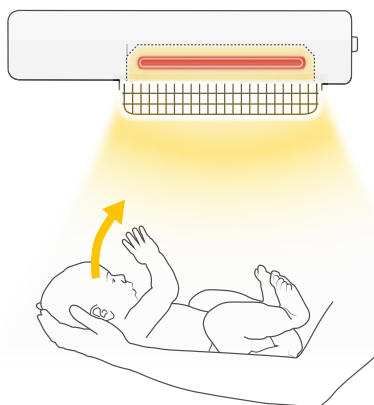

## Integrated safety

For cost reasons many radiant warmers in the market do not provide essential safety features. A part of their exposed surfaces can become dangerously hot because they do not have efficient protection, switch-off and warning devices.

Not so the radiant warmers CERAMOTHERM 3000! They have been designed under consideration of the current standards and according to the principle of integrated safety in order to minimize all possible risks by facile but effective technique. So the heating elements are arranged safely behind a finger-touch protection and prevent active children, operators and other persons from touching the 200 - 600 °C hot heating element. The heating elements are shatter-proof so no risk can arise from them.

Furthermore, the risk of hazard for the operator by sharp edges and corners are minimized by the rounded design. So the operator is protected from injuries.

# CERAMOTHERM® 3000



## Application with maximum safety

The infrared spectrum of the radiant warmers CERAMOTHERM was chosen in a way that on one hand the patients are warmed efficiently and on the other hand it cannot cause any injuries to the eye and the skin, expert use provided.

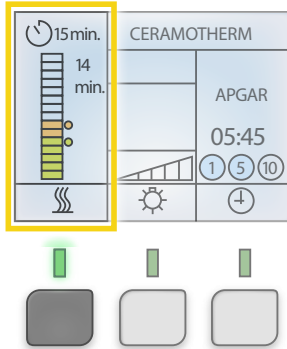

Very small or hypothermic patients often require high radiation intensity to maintain their body temperature. In most cases this is above  $10 \text{ mW/cm}^2$  which in the long run can cause hyperthermia and skin injuries. In order to avoid such hazards after a certain time the radiation intensity is automatically reduced to a safe value and a signal sounds to inform the operator. So cooling is avoided and the patient is prevented from hypothermia. The actual intensity and balance time to automatic intensity reduction are displayed.

As the heating elements can remain hot sometime after switching off, the residual intensity is displayed until cooling off.

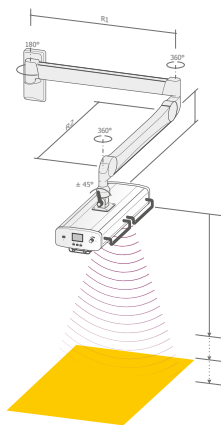

## Autodetect function for height-adjustable radiant warmers, constant intensity for the patient

Radiant warmers CERAMOTHERM with height-adjustable wall or ceiling fixtures have an automatic distance detection with patented intensity compensation Autodetect. For other applications this function is available as option.

The Autodetect function will immediately reduce the radiation intensity when the distance to the patient is reduced and it will automatically increase the intensity within shortest time when the distance to the patient is enlarged. The parameters for intensity and distance are displayed accordingly. This is a unique technique which is second to none.

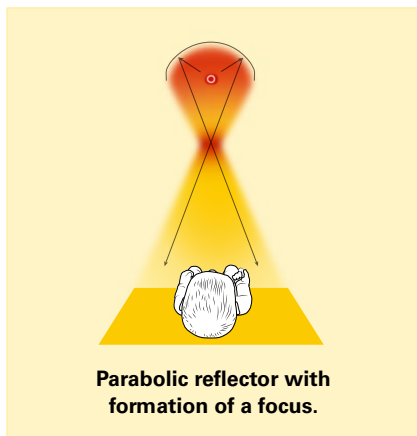

## The reflector

Radiant warmers CERAMOTHERM have a high-performance reflector that directs the radiation intensity of the heating element directly and evenly to the patient pad. Formation of a hazardous focus is excluded.

Parabolic reflectors with a focus below the radiant warmer are a hazard for the operator and a thing of the past.

# CERAMOTHERM 3000 in two sizes

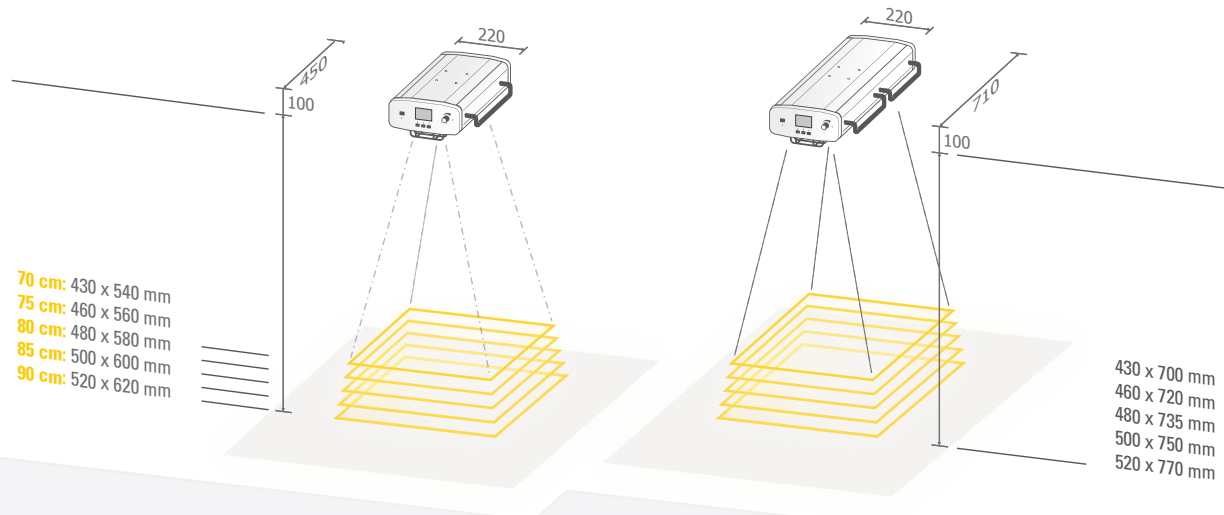

## CERAMOTHERM 3100

CERAMOTHERM 3100 with 1 heating element, mainly for babies during postnatal care, nappy changing and examination as well for application in the care sector. The device is also suitable for partial warming of body parts.

## CERAMOTHERM 3200

CERAMOTHERM 3200 with 2 heating elements, covering a larger area. Safe application for pre-term infants, babies, infants and adults as well as for pre-warming of patient beds.

## Sensible convenient warming during care, nappy changing, examination

It must be avoided that in particular unclothed new-born infants loose body heat.

During postnatal care and after bathing there is a considerable heat loss by convection. Often the infant does not feel comfortable and cries or even cools down. Considering that only by removing the nappy up to 20% of the body heat is lost, baby changing areas should be kept cosy and warm for a longer period.

Radiant warmers CERAMOTHERM 3000 provide well-being for the small patients. Babies that are not cold, are much more relaxed and calm during treatment, nappy changing and examination. So the parents are encouraged to play with their unclothed baby for a while or to give him a massage.



# Warming - wherever it is required

## Wide range of fixtures

Radiant warmers CERAMOTHERM 3000 can be mounted at the wall, the ceiling or a mobile stand. Keeping in mind the intended use and constructional conditions a wide range of fixtures can be chosen for the individual application.

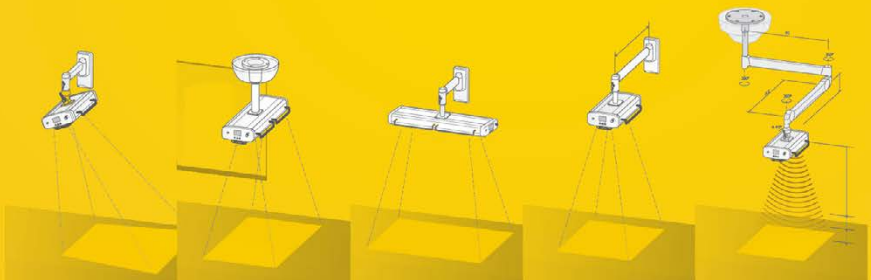
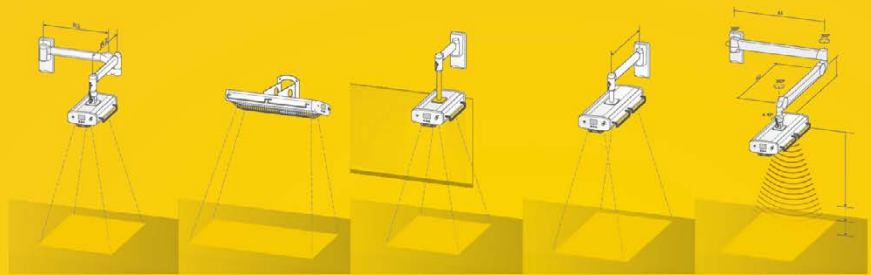

## Static arrangement to the patient pad

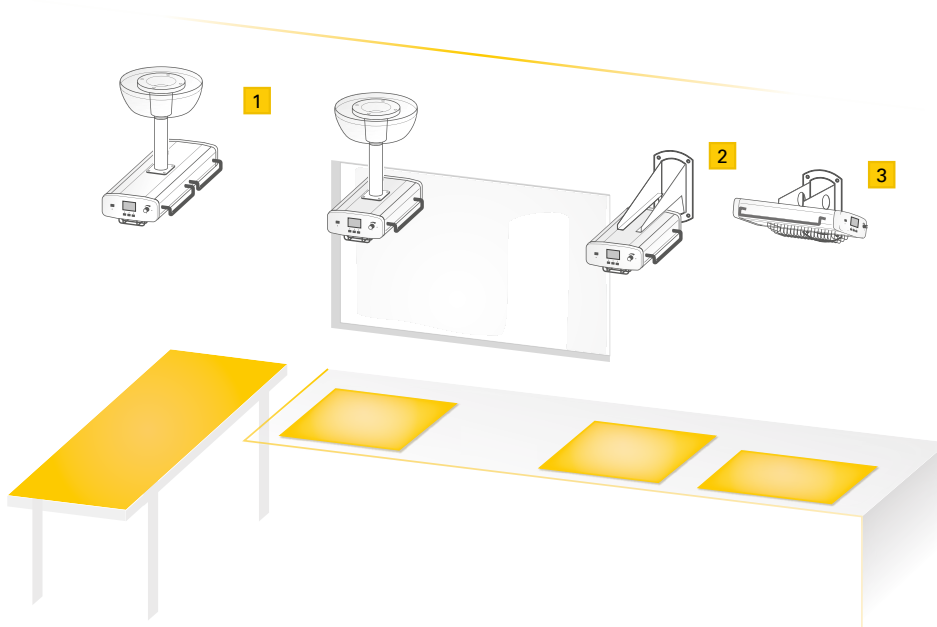

- 1 Ceiling bracket, distance between patient pad and bottom edge of solid ceiling max. 2600 mm**

CERAMOTHERM 3100  
Order No. WY3117

CERAMOTHERM 3200  
Order No. WY3217

In case of larger distance to the solid ceiling a connection flange B0329 is required. Refer to mounting information on page 14.

- 2 Wall holder**

CERAMOTHERM 3100  
Order No. WY3115

- 3 Wall holder, lateral mount**

CERAMOTHERM 3100  
Order No. WY3116

CERAMOTHERM 3200  
Order No. WY3216



## Swivelling wall arms

For applications where it is not necessary to adjust the distance between patient pad and radiant warmer, wall arms in 3 lengths are available which can be swivelled  $\pm 90^\circ$ . The radiant warmer can be rotated by  $360^\circ$  and locked in the desired horizontal position. As option these arms can also be equipped with vertical extension and vertical adjustment.

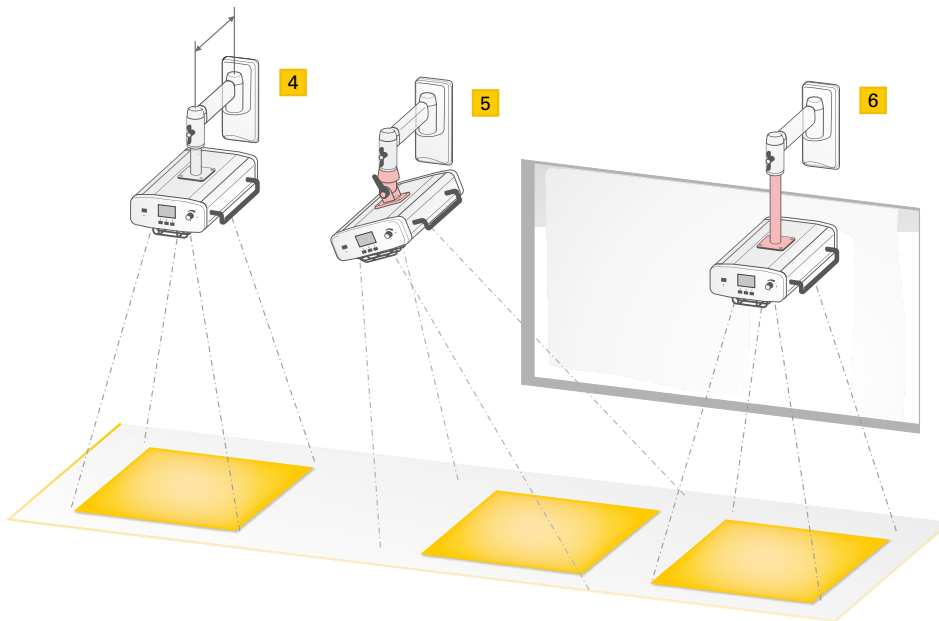

**4** Horizontal swivelling  $\pm 90^\circ$  and lockable, warmer rotatable  $360^\circ$

Wall arm 320 mm length  
CERAMOTHERM 3100  
Order No. WY3101

CERAMOTHERM 3200  
Order No. WY3201

Wall arm 480 mm length  
CERAMOTHERM 3100  
Order No. WY3102

CERAMOTHERM 3200  
Order No. WY3202

Wall arm 600 mm length  
CERAMOTHERM 3100  
Order No. WY3103

CERAMOTHERM 3200  
Order No. WY3203

**5** Upgrade option:  
Vertical adjustment  $\pm 45^\circ$   
Order No. WY1822

**6** Upgrade option:  
Vertical extension  
by 250 mm  
Order No. WY1846

## Arrangement examples

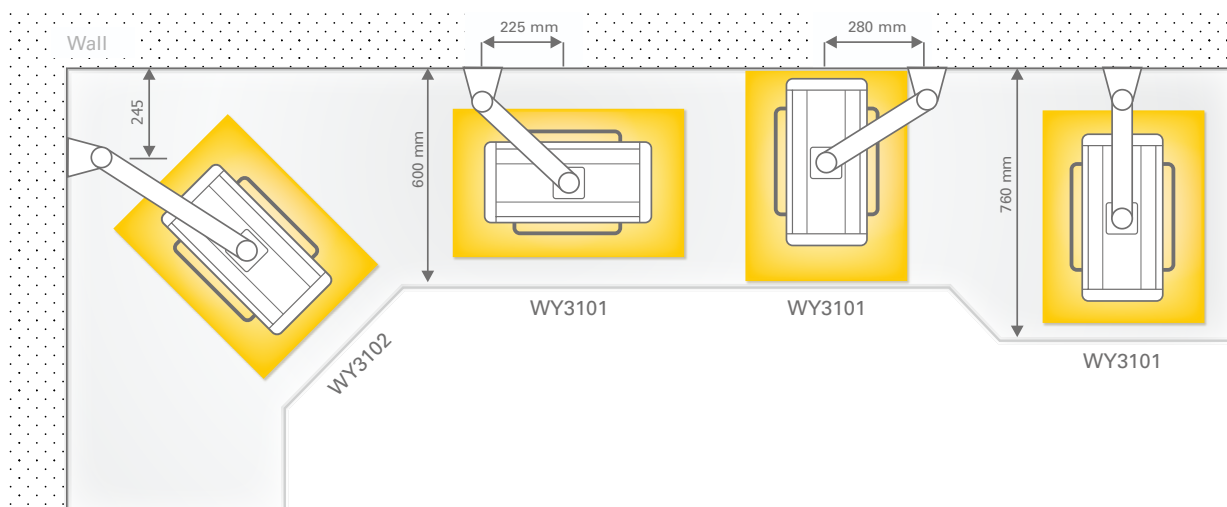

# CERAMOTHERM® 3000

## Further arrangements

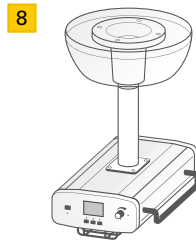
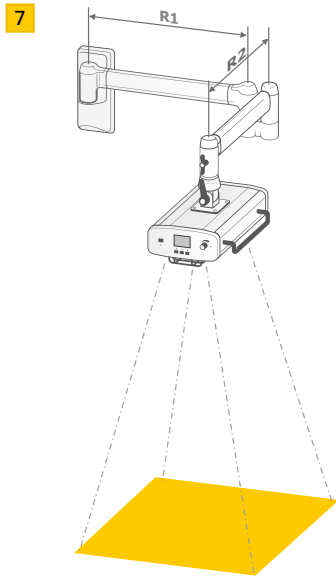

- 7** Double-joint wall arm, R1 = 480 mm, R2 = 480 mm, Wall arm swivelling  $\pm 90^\circ$  and lockable, warmer rotatable  $360^\circ$ , vertical adjustment  $\pm 45^\circ$

CERAMOTHERM 3100  
Order No. WY3104

CERAMOTHERM 3200  
Order No. WY3204

**Option:**

R1 = 320 or 600 mm  
R2 = 320 or 600 mm

- 8** Ceiling bracket, distance between patient pad and bottom edge of solid ceiling max. 2600 mm

CERAMOTHERM 3100  
Order No. WY3117

CERAMOTHERM 3200  
Order No. WY3217

In case of larger distance to the solid ceiling a connection flange B0329 is required. Refer to mounting information on page 14.

## Height-adjustable double-joint arms

Double-joint arms allow an adjustment in nearly any position within the moving range to the patient pad. In addition they provide a vertical adjustment and Autodetect function.

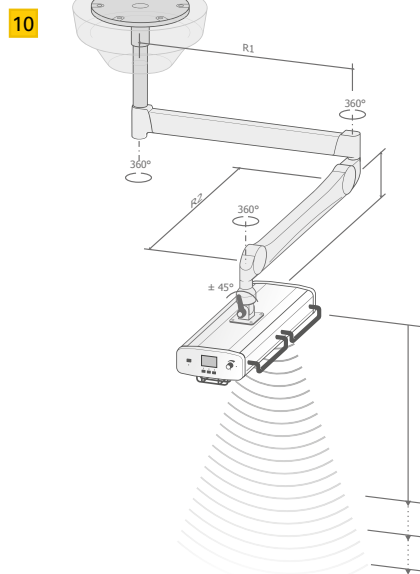
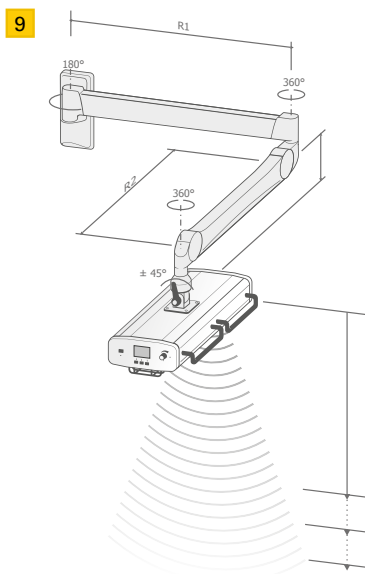

- 9** Double-joint wall arm Extension arm R1 = 750 mm, height-adjustable spring balanced arm R2 = 800 mm, adjustable stop for highest position warmer rotatable  $360^\circ$  vertical adjustment  $\pm 90^\circ$

CERAMOTHERM 3100  
Order No. WY3107

CERAMOTHERM 3200  
Order No. WY3207

**Option:**

Extension arm R1 = 950 mm  
Order No. WY1847

- 10** Ceiling bracket with double-joint arm, Extension arm R1 = 750 mm, height-adjustable spring balanced arm R2 = 800 mm, adjustable stop for highest position, warmer rotatable  $360^\circ$ , vertical adjustment  $\pm 90^\circ$ , distance between patient pad and bottom edge of solid ceiling max. 2600 mm

CERAMOTHERM 3100  
Order No. WY3108

CERAMOTHERM 3200  
Order No. WY3208

In case of larger distance to the solid ceiling a connection flange B0329 is required. Refer to mounting information on page 14.

## For each field the right solution

A variety of components are available for realizing special solutions. A combination of examination light or phototherapy device with a radiant warmer is possible as well as a combination of radiant warmers for a central baby-changing area.

## Flexible - heat everywhere

Radiant warmers often need to be arranged completely flexible, either to allow the patient the required elbow room or to warm certain body parts or to swivel them into parking position after use.

For mobile nursing beds or height-adjustable examination stretchers in most cases a radiant warmer with swivel facility and variable height is necessary. The same applies for the operation theatre, in order to prevent patients from cooling down during preparation and recovery.

For these applications a double-joint arm with large swivel range and flexible fixing head brings the radiant warmer in any desired position to the patient. This variant is available as wall or ceiling mount.

In connection with height-adjustable systems it must be considered that the radiation intensity emitted to the patient will decisively change according to the distance between radiant warmer and patient. The shorter the distance, the higher the intensity and vice versa.

The patented distance detection Autodetect with automatic intensity compensation balances distance variations quickly. It also guarantees that below a safety distance the heating is switched-off automatically and any hazard for the patient is excluded.



Patented distance detection with automatic intensity compensation





## CERAMOTHERM 3000 for mobile use

As an option to radiant warmers mounted at the wall or the ceiling, a mobile radiant warmer is recommendable when the device shall be used at different places or in different rooms or if due to constructional reasons a mounting is not possible.

The height-adjustable stand is mobile on four antistatic castors, two of them can be locked.

Due to the low height of the pedestal the radiant warmer can also be used at patient beds or operating theatre tables. The V-shape allows an optimum utilization of the room. Differently to usual 5-foot pedestals the paths for the personnel are kept clear which prevents accidents. In order to place the radiant warmer at the optimum distance to the patient, a distance mark is provided which must be adjusted to the level of the patient pad. So the safety distance between radiant warmer and patient is guaranteed at any time.

**Mobile stand, adjustable to  
patient level 600 to 1000 mm,  
warmer rotatable 360°,  
vertical adjustment  $\pm 90^\circ$**

CERAMOTHERM 3100  
Order No. WY3112

CERAMOTHERM 3200  
Order No. WY3212

# Ordering information

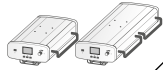

Order No.	CERAMOTHERM 3100		CERAMOTHERM 3200		Automatic distance detection	Weight (kg) complete	Torque (Nm)	Static, distance between patient pad and solid ceiling max. 2600 mm	Ceiling bracket			Wall arm			Double-joint wall arm	Ceiling bracket with double-joint arm, height-adjustable	Mobile stand, height-adjustable	Options
	4.8 kg	6.8 kg	Static	320 mm length					480 mm length	600 mm length	R1 = 480 mm, R2 = 480 mm	Height-adjustable, R1 = 750 mm, R2 = 800 mm	Distance between patient pad and solid ceiling max. 2600 mm	Distance between patient pad and solid ceiling above 2600 mm				
WY3101	•			8.8	27			•										
WY3102	•			9.2	39				•									
WY3103	•			9.4	48					•								
WY3104	•			12.8	90						•							
WY3107	•		•	17.8	181								•					•
WY3108*	•		•	27.4	171									•				
WY3112	•			22.3	–										•			
WY3115	•			7	17				•									
WY3116	•			6.3	11				•L									
WY3117*	•			12.3	56	•												
WY3201		•		10.9	35				•L									•
WY3202		•		11.2	50					•								•
WY3203		•		11.4	62						•							•
WY3204		•		14.8	111							•						•
WY3207		•		19.8	214								•					•
WY3208*		•		29.9	202									•				•
WY3212		•		23.3	–										•			
WY3216		•		8.3	16				•L									
WY3217*		•		14.3	59	•												
B0329*				30 <sub>kg/m</sub>										•				
M0369				2.1														

L = Lateral mount

\* When ordering please indicate dimensions:

- Floor to top line of patient pad
- Floor to bottom line of suspended ceiling
- Floor to bottom line of solid ceiling

Please observe the mounting information on page 14.

# Mounting information

## Wall mount with flexible arrangement to the patient pad

Mounting in solid brickwork, lime sandstone, concrete, according to the national construction standards.

In agreement with the architect or engineering office cavity and light-weight construction walls must be reinforced as follows: Height 600, width according the distance between the posts. Material: Sheet steel min. 2 mm thick or multiplex plate min. 35 mm thick, screwed in place from post to post.

As an alternative, for double-planked plasterboard walls (2 x 12.5 mm) the external wall arm bracket support order No. M0369 may be used. In that case expansion anchors Hilti HDD-S 8 or equivalent must be used and the wall arm bracket must be screwed in place on the wall arm bracket support by min. 2 x M6 (8.8) screws.

Order No. WY3101, WY3102/3202, WY3103/3202, WY3104/3204, WY3107/3207

## Ceiling mounts

Mounting at the solid ceiling

**Static:** Distance between patient pad and bottom line of solid ceiling max. 2600 mm respectively distance between solid ceiling and suspended ceiling max. 500 mm.

Order No. WY3117, WY3217

**Height-adjustable:** Distance between patient pad and bottom edge of solid ceiling max. 2600 mm respectively distance between solid ceiling and suspended ceiling max. 500 mm.

Order No. WY3108, WY3208

In case of distance between patient pad and bottom line of solid ceiling above 2600 mm respectively distance between solid ceiling and suspended ceiling above 500 mm a connection flange B0329 is required in addition.

# Technical Data

## Radiant warmer

	CERAMOTHERM WY3100	CERAMOTHERM WY3200
Depth	450 mm	710 mm
Width	220 mm	220 mm
Height	100 mm	100 mm
Weight without mount	4.8 kg	6.8 kg

## Distance radiant warmer to the patient pad

	CERAMOTHERM WY3100	CERAMOTHERM WY3200
Wall and ceiling mounts, fixed height	900 mm	900 mm
Wall and ceiling mounts, height adjustable	650 - 900 mm	650 - 900 mm
Mobile stand, height-adjustable	650 mm	650 mm
Safety distance to the patient pad	650 mm	650 mm
Factory setting to distance 650 - 900 mm possible	Yes	Yes

## Performance and operating data

	CERAMOTHERM WY3100	CERAMOTHERM WY3200
Operating voltage / power supply	230 V – 50/60 Hz	230 V – 50/60 Hz
Max. power input	690 W / 3 A	900 W / 3,9 A
Heating element(s), ceramic, life >10 years	1 x 600 W	2 x 400 W
Wave length spectrum	1.5 to 6.8 µm	1.5 to 6.8 µm
Illumination	on both sides	on both sides
Dimmable	in 5 steps	in 5 steps
Capacity	2 x 5.5 W	2 x 18 W
Illumination intensity (max.)	2 x 850 lm	2 x 1350 lm
Colour temperature	4000 K	4000 K
Intensity selection display	Yes	Yes

Actual intensity and residual heat display	Yes	Yes
Alarm for intensity deviation +/- 2mW/cm <sup>2</sup>	Yes	Yes
Alarm / automatic intensity reduction after 15 minutes > 10 mW/cm <sup>2</sup>	Yes	Yes
can be switched-off temporarily	Yes	Yes
Power failure alarm	Yes	Yes
Distance detection for height-adjustable wall or ceiling mounts	Yes	Yes
Intensity compensation for distance detection	Yes	Yes
Automatic switch-off below the safety distance	Yes	Yes

#### Irradiated area at distance to patient pad

	CERAMOTHERM WY3100	CERAMOTHERM WY3200
650 mm	390 x 520 mm	390 x 680 mm
700 mm	430 x 540 mm	430 x 700 mm
750 mm	460 x 560 mm	460 x 720 mm
800 mm	480 x 580 mm	480 x 730 mm
850 mm	500 x 600 mm	500 x 750 mm
900 mm	520 x 620 mm	520 x 770 mm

#### Intensity selection at distance to patient pad

	CERAMOTHERM WY3100	CERAMOTHERM WY3200
650 mm	2 to 30 mW/cm <sup>2</sup>	2 to 30 mW/cm <sup>2</sup>
700 mm	2 to 26 mW/cm <sup>2</sup>	2 to 30 mW/cm <sup>2</sup>
750 mm	2 to 22 mW/cm <sup>2</sup>	2 to 26 mW/cm <sup>2</sup>
800 mm	2 to 20 mW/cm <sup>2</sup>	2 to 22 mW/cm <sup>2</sup>
850 mm	2 to 18 mW/cm <sup>2</sup>	2 to 20 mW/cm <sup>2</sup>
900 mm	2 to 16 mW/cm <sup>2</sup>	2 to 18 mW/cm <sup>2</sup>

#### Colours

	CERAMOTHERM WY3100	CERAMOTHERM WY3200
Radiant warmer	White RAL 9010	White RAL 9010
Handles of radiant warmer	RAL 3003 (other colours available at choice)	RAL 3003 (other colours available at choice)
Wall and ceiling mounts	White RAL 9010	White RAL 9010
Pedestal of mobile stand	White RAL 9002	White RAL 9002

#### Technical data mobile stand

	Mobile stand (Order No. WY3112, WY3212)
Depth	560 mm
Width	560 mm
Height	1535 to 1935 mm
Necessary under-pin height	> 95 mm
Castors / kickstop	2 x Ø 75 mm, 2 x Ø 65 mm / 2 x
Adjustable to patient level	600 to 1000 mm
Distance mark	Yes

## Classification and standards

	CERAMOTHERM WY3100	CERAMOTHERM WY3200
Protection class	1	1
MDD-class	Ila	Ila
Standards	EN 60601-1: 2006 EN 60601-1-2:2007 EN 60601-2-21:2009* *Particular requirements for basic safety of infant radiant warmers	EN 60601-1: 2006 EN 60601-1-2:2007 EN 60601-2-21:2009* *Particular requirements for basic safety of infant radiant warmers

# Warming wherever it is required



**Weyer GmbH**

Herrenhöhe 4, D-51515 Kürten-Herweg / Germany

Tel.: (+49) 02207 9698-0

Fax.: (+49) 02207 4750

E-Mail: [info@weyermed.com](mailto:info@weyermed.com)

[www.weyermed.com](http://www.weyermed.com)

